



Monodraught



WINDCATCHER®

NATURAL VENTILATION

Sustainable, low energy building ventilation



THE QUEEN'S AWARDS
FOR ENTERPRISE:
INNOVATION
2018



We are Pioneering British Greentech

We are pioneers in the design and manufacture of advanced sustainable ventilation, cooling, heating and lighting solutions for new and refurbished commercial buildings. We deliver outstanding temperature-control and indoor air quality whilst minimising the consumption of both electricity and refrigerants so as to reduce our carbon footprint. Monodraught have over 45 years' experience and our products have saved the equivalent of nearly 390,000 tonnes CO₂ over the last two decades, which is equivalent to over 3,534 million miles in a small car*.

Monodraught believe that every business has a responsibility to invest in local communities. We purchase over 85% of our materials from suppliers within a 100-mile radius and recycle where possible. Our caring team supports many charitable causes, and Monodraught are proud partners of the local mental health charity, Buckinghamshire Mind.



DESIGNED &
MANUFACTURED
IN BRITAIN

* Based on 110g CO₂ per mile emitted from a typical a small family car.

CONTENTS

Our challenge	3
About natural ventilation	4
Product range	5
Why choose natural ventilation?	7
Product features	8
Working every season	13
Key features	14
System options	15
Ventsair	16
No-leak guarantee	17
Case studies	18
Our sustainable product range	22
Monodraught: with you all the way	23

Awards & Accreditations

Trading for over 45 years, we are proud to be recognised with many awards.



THE CLIMATE CHANGE REALITY

Greenhouse gas emissions continue to drive global warming and the five-year period to 2018 was the hottest ever recorded. The world is nearly one degree warmer than it was before widespread industrialisation, and the 20 warmest years on record have been in the past 22 years according to the World Meteorological Organization (WMO).

According to the Committee on Climate Change if the global temperatures rise by 2°C, around 2.6 million people in the UK will be impacted by the significant risk of flooding.

OUR CHALLENGE

The UK government has now legislated for net zero carbon by 2050. Here at Monodraught, we are fully committed to playing our part and live by our green principles.

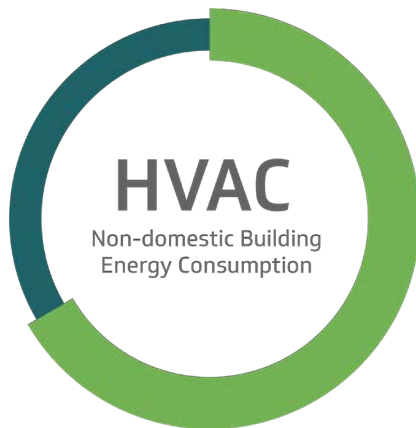

Achieving net zero by 2050 will mean virtually eliminating emissions from the UK's building stock. According to BEIS, two thirds of the energy consumption from the 1.8 million non-domestic buildings in England and Wales was used to provide building services (heating, ventilation, cooling, hot water and lighting).*

Higher standards in design and construction are crucial to drive down carbon emissions. We must urgently transition to low energy ventilation, heating, cooling solutions and Monodraught are here to help.

**Source: BEES Executive Summary BUILDING ENERGY Nov 2016*



ABOUT NATURAL VENTILATION

Natural ventilation supplies fresh air to a building or room by utilising the passive effects of wind speed or differences in internal and external air pressure. It is a sustainable, low carbon ventilation system that does not use fans or pumps making it extremely cheap to run whilst providing a comfortable and healthy indoor environment.

Monodraught first launched Windcatcher in 1991 and have been constantly innovating our concept for modern applications. In the last two decades nearly 27,000 Monodraught Windcatcher units have been successfully sold and installed in UK, France, USA and New Zealand.

WINDCATCHER SOLVES PROBLEMS

Early naturally ventilated buildings relied purely on a passive stack that acted like a “chimney stack” to exchange indoor and outdoor air. However, its effect was limited especially on peak summer days because the temperature in the passive stack has to be some 10°C above the room temperature, and often led to overheating.

Windcatcher is more than just a passive stack. Its unique design incorporates wind driven air intakes to generate a positive pressure in the room below, which together with temperature differences, assist the passive stack to exhaust the stale room air.

Best in class, Monodraught Windcatcher have an enviable reputation having performed consistently, effectively and reliably over the last 2 decades.



Windcatcher applications

Windcatcher is the perfect solution for new or refurbished buildings that require the benefits of sustainable, low carbon and secure natural ventilation.

- School classrooms, dining rooms, science rooms
- Lecture halls and libraries
- Sports halls
- Offices and reception areas
- Visitor centres and restaurants
- Prisons



OUR NATURAL VENTILATION PRODUCT RANGE

X-Air



Windcatcher X-Air

Features our patented Activlouvre modulating aerofoil louvres. Also available with Ventsair cowl. Available in square only. Backed by a 10-year no leak guarantee*



Sola-boost X-Air

Enhanced with solar panels within the capping that power a fan within the central core.



Windcatcher Zero

Incorporates an integrated 'Air to Air' core mounted heat exchanger technology and PV panels that power a boost ventilation fan. Similar in appearance to Sola-Boost X-Air.

Classic

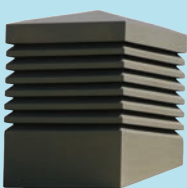

Windcatcher Classic

The original sustainable natural ventilation system with motorised volume control damper and without mechanical fans. Internal dividers optimise the stack effect. Shapes: square, oval, rectangular, circular, heritage and bespoke. Backed by a 10-year guarantee*



Sola-boost Classic

The Windcatcher Classic is enhanced with solar panels within the capping that power a fan within the central core. The fan can be used both as boost ventilation or as an extract fan.

* T&C's apply





OUR VENTSAIR PRODUCT RANGE

Ventsair systems are mainly used to encourage cross flow ventilation within a room, usually where the aspect is too deep for openable windows or other wall openings to work efficiently.

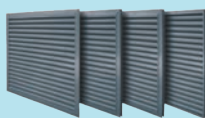

Ventsair Façade (VAF)

Designed for façade installation. Comprised of an external aluminium louvre, a volume control damper and an internal grille.



Acoustic air transfer system

An internal wall mounted system that promotes cross flow ventilation within rooms to reduce heat build-up.

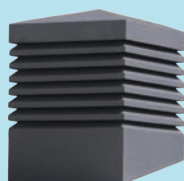

Roof Mounted Terminal

With similar external appearance to the Windcatcher Classic, the internal configuration has no internal dividers and simply acts as an intake or exhaust system. Available in square shape only.

WHY CHOOSE NATURAL VENTILATION

Advantages for Specifiers



Proven track record

Based on principles original used by the Persians and Arabians, Monodraught's Windcatchers have been in operation in buildings for over 20 years



Enhances your energy and carbon saving credentials

Ventilation with extremely low power consumption



Extremely quiet in operation

Since there are no fans and only small motors for the dampers, noise is not an issue



Easy to integrate

A wide range of enhanced types to suit every application

Advantages for Building Owners



Contributes towards sustainability targets

Low energy ventilation helps to achieve Regulations, BREEAM ratings and funding criteria



No running costs

Once installed, there are extremely low running costs over the life of the building (electrical consumption for controls and dampers only on certain models)



Easy to maintain

Since there are no moving parts, there is nothing to wear out or break down



Fast payback

Low energy costs with minimal maintenance requirements and long service life give an impressive payback which releases capital for other projects

Advantages for Contractors



Enhances your energy and carbon saving credentials

Low carbon ventilation with extremely low / zero energy consumption



Easy preparation

Simplified wiring



Robust and easy to install

Powder coated steel frame



Easy preparation

230V AC mains with switched fused is all that is needed for our commissioning team

Advantages for Occupants



Healthy indoor environment

Natural ventilation brings a steady supply of fresh air into the building, topping up oxygen levels, whilst at the same time expelling stale air



Quiet with no noise disruption

Minimum mechanical operation together with acoustic panels minimise daytime noise levels



Sustainable energy

Natural ventilation harnesses the wind and minimises impact on the environment



Easy to use

Simple control options provides occupant autonomy

WINDCATCHER X-AIR

Monodraught's patented Activlouvre® modulating aerofoil louvre technology combines a static external louvre and a modulating internal louvre. They work together to vary the opening and free area. Maximum ventilation rates are achieved when the louvres are fully open. Weather resistance is increased when they are partially modulated. Alternatively, they can be closed to prevent the ingress of precipitation.

External air catchment fins provide greater area at the louvre which improves performance in relation to wind speed. Pressure release vanes at the fins reduce face pressure during high winds.

With over 5,300 systems successfully installed, the Windcatcher X-Air is backed-up by our 10-year no leak guarantee*.

How does it work?

It doesn't matter which way the wind blows, the louvres always encapsulate the prevailing wind. The internal dividers split the system into four quadrants and turn the air movement down through 90 degrees. Stack effect is achieved as a result of the difference between the air temperature inside and outside of a building - and the subsequent imbalance effect on air density and pressure gradient of the internal and external air masses results in the warm air rising up through the quadrants, dispersing to the atmosphere.

* T&C's apply



SOLA-BOOST X-AIR

Solar-boost X-Air has an integrated DC solar powered fan and offers enhanced energy and carbon savings over Windcatcher X-Air with Monodraught's patented Activlouvre® aerofoil technology as standard.

During normal weather conditions, natural ventilation is provided without any energy consumption. During sunny conditions, a 40W solar PV module situated within the system capping powers the fan. Our patented LINC PowerTrack system delivers a smooth current to maximise the performance of the solar powered fan and increases the fan speed by up to 250%. Other features include external air catchment fins, pressure release vanes and optional solar powered architectural lighting.

Maximum efficiency can be achieved by ensuring the solar panel is installed south facing.



WINDCATCHER X-AIR & SOLA-BOOST X-AIR OPERATION MODES

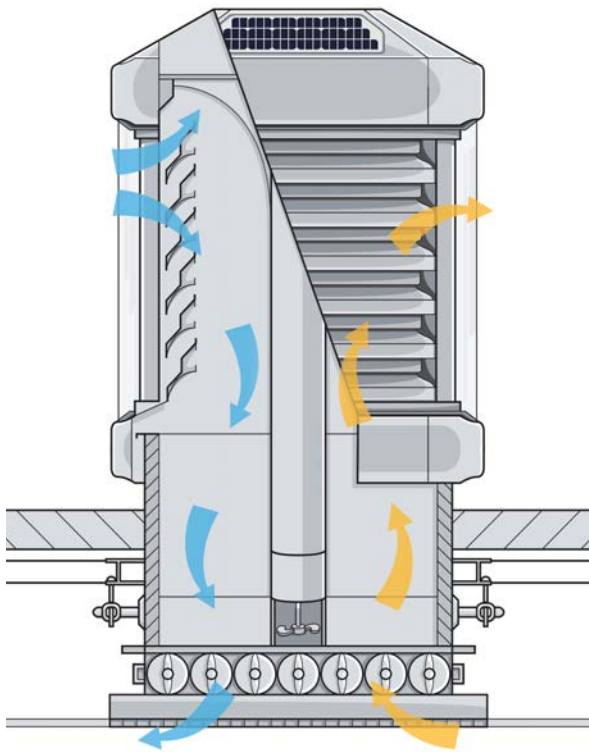

Natural Ventilation

External temp $>15^{\circ}\text{C}$ and internal temp $>21^{\circ}\text{C}$ or $\text{CO}_2 >1000\text{ppm}$

The X-Air Thermal Mixing Unit can provide natural ventilation through the buoyancy of the internal air and wind pressures exerted upon the system at roof level. Warm air is extracted through the leeward side of the system due to the negative pressure upon the roof terminal. Fresh air is entrained in the windward side.

Boost Fan

External temp $>15^{\circ}\text{C}$ and internal temp $>26^{\circ}\text{C}$ or $\text{CO}_2 >1400\text{ppm}$

The X-Air Thermal Mixing unit can supply boosted ventilation during daytime conditions, when the internal temperature is greater than 26°C to supplement natural ventilation and to ensure good internal air quality.

Additionally during summer time periods supplemented night time cooling can be provided.

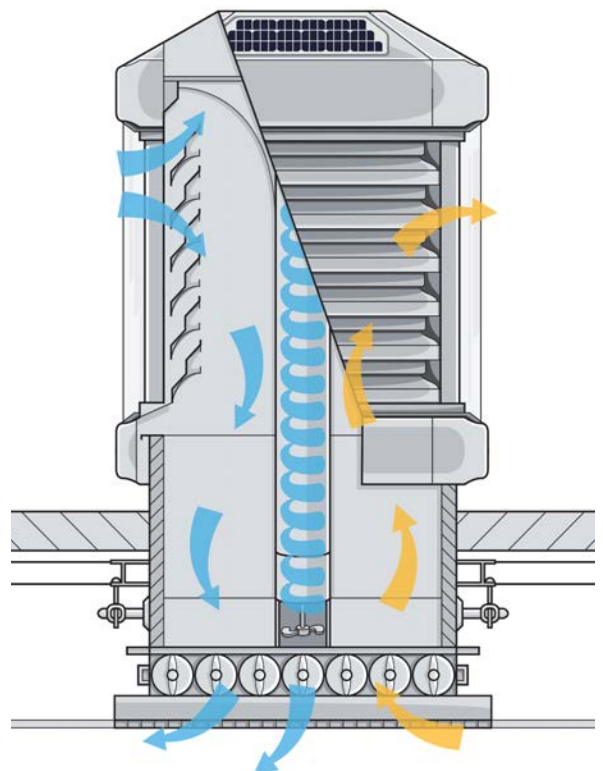

WINDCATCHER ZERO

Our latest natural ventilation product provides exceptional comfort and energy consumption through a range of optimised heat recovery modes.

The new Windcatcher Zero provides natural ventilation with heat recovery technology using an integrated counterflow heat exchanger and a robust intelligent control strategy. The adaptive controls sense air quality in real time and seamlessly switch between energy efficient modes: natural, mechanical, and heat recovery ventilation.

The 60W solar PV panels run boost ventilation fans, and even during very low wind speed periods, ventilation requirements are achieved efficiently without consuming electricity. A volume control damper, inlet air filters and datalogging are provided as standard.

With Windcatcher Zero smaller and fewer heat emitters are necessary within the occupied spaces thereby reducing the size of the heat emitters required, reducing overall boiler loads, providing a net benefit in Part L calculations against conventional natural ventilation and minimising heating running costs.



How does it work?

Windcatcher Zero utilises an integrated 'Air to Air' core mounted heat exchanger within the natural ventilation system and automatically varies between natural ventilation and heat recovery modes, or a combination as necessary.

During very hot summer periods, natural ventilation provides night time cooling to the internal spaces. During the following day, if the external inlet air temperature is higher than the indoor room temperature, the unique Windcatcher Zero heat recovery core is automatically activated to deliver cooler ventilation air and minimise the summer time room temperatures.

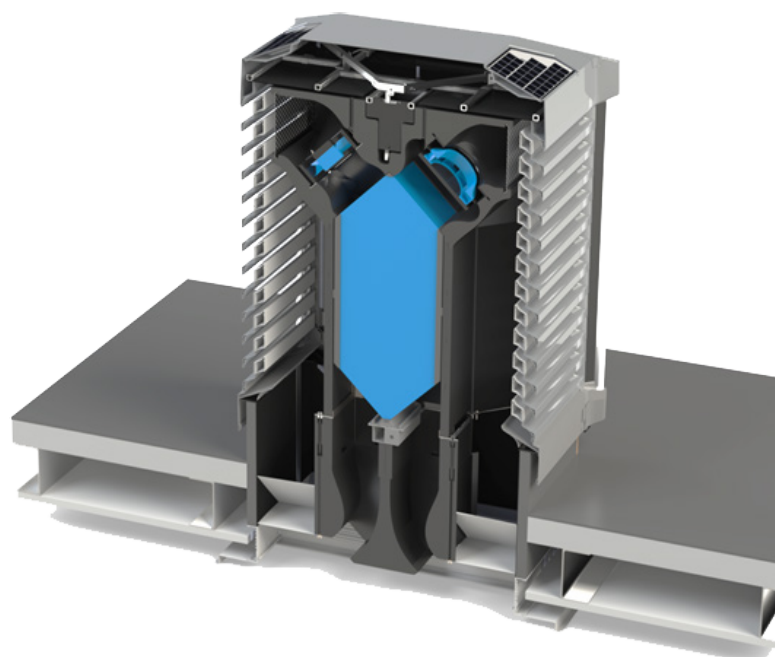

Patent Pending - 1917112.3

WINDCATCHER ZERO OPERATION MODES

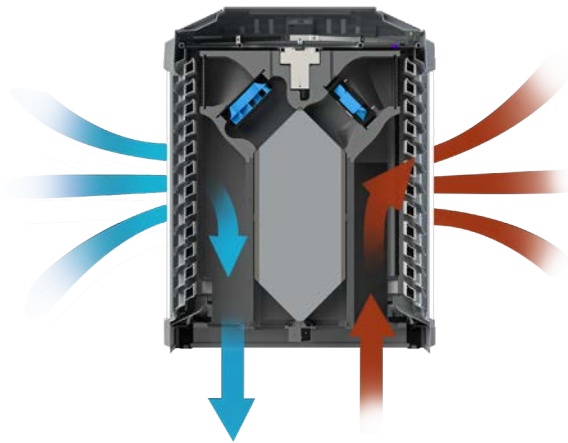

Natural Ventilation

The Windcatcher system encapsulates the prevailing wind, and turns that wind movement through 90° in to the space. Fresh air is brought into the room and stale air is expelled using the negative pressure on the leeward side of the Windcatcher as well as the buoyancy and stack effect of warmer air rising within the space.

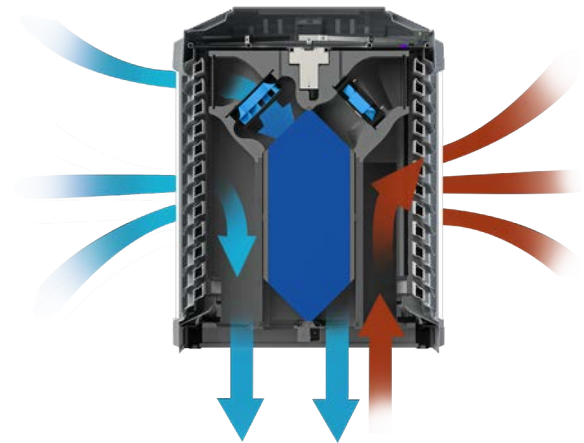

Boost Fan

Utilising the PV panels the Windcatcher Zero can provide a boosted ventilation rate without the use of grid power. This ensures that even when there are periods of very low wind speed the ventilation rates required are met.

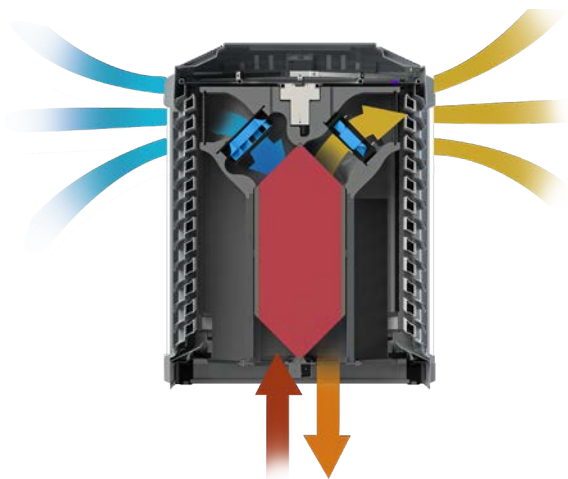

Heat Recovery

To avoid cold draughts, when the temperature of the outside air is lower than the internal, the Windcatcher Zero can deliver tempered air via the 'Air to Air' heat recovery core. The counter flow core enables efficient exchange of heat from the stale exhaust air through an ultra-thin aluminium membrane. The high efficiency core and low power fans automatically minimises the heating requirements whilst optimising air quality.

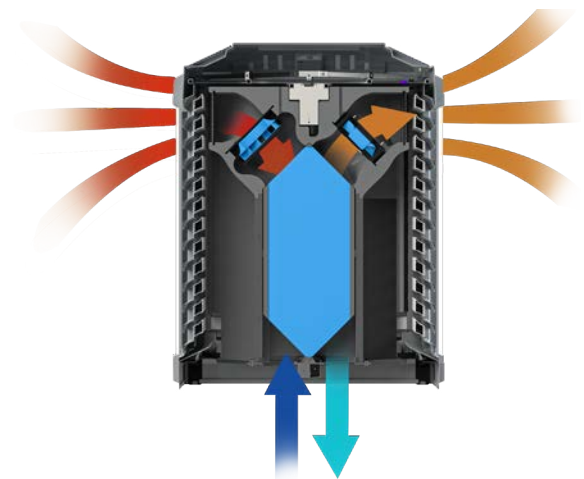

Cool Recovery

The Windcatcher Zero can maintain a greater level of comfort conditions compared to conventional natural ventilation systems. To keep an internal space cooler during hot periods The Windcatcher Zero can cool the incoming fresh air by utilising the 'Air to Air' heat recovery core. The efficient recovery of cold from the exhausted air reduces room temperatures when compared to natural ventilation or reduces demand on auxiliary cooling systems.

WINDCATCHER

The original, sustainable natural ventilation system is a simple and effective design that provides fresh air during the day as well as night-time cooling.

It combines the benefits of both top-down and passive stack ventilation with very low electrical consumption by means of very low energy motorised volume control dampers.

The prevailing wind is encapsulated and turned down through 90°. Fresh air is brought into the room and stale air is expelled using the natural energy of buoyancy and stack effect common to all natural ventilation systems.

Available in a wide range of standard square sizes, as well as bespoke shapes to suit any project.

When enhanced with Monodraught's iNvent 2 control system and managed by our proven control strategy, it achieves temperature and CO₂ demand-controlled ventilation. External louvres are protected internally by Trilayer® Weather Protection.



SOLA-BOOST

This sustainable natural ventilation system is based on the original Windcatcher Classic. It uses no electrical energy and combines the benefits of both top-down and passive stack ventilation with a DC solar powered fan.

The unit is divided internally into four quadrants. The simple and effective design provides fresh air during the daytime as well as secure night time cooling.

The 40W PV solar module powers the fan can either bring fresh air from the outside or expel the stale air from the room. Our LINC PowerTrack control system delivers a steady current to maximise the performance of the solar powered fan.

This flexible system can be tailored to suit the needs of almost any application and has been proven in schools, colleges, healthcare environments and commercial properties.



WORKING IN EVERY SEASON



Natural Ventilation

Fresh air is brought into the room and stale air is expelled using the negative pressure on the leeward side of the Windcatcher as well as the buoyancy and stack effect of warmer air rising within the space.



Night-time and Mid-season operation

The Windcatcher will continue to operate during mid-seasons, in the evenings or at weekends, when the building is unoccupied, providing all the benefits of this “free air conditioning”.

In night-time cooling mode the system utilises cooler night-time air to remove heat from the fabric of the building and cool the room ready for the next day. Volume control dampers at the base of the system precisely control the amount of airflow through the system. If the internal temperature falls below 15°C the dampers automatically close to prevent over cooling.



Summer operation

In the summer months, warm air naturally rises to the ceiling and out of the system. At the same time, any prevailing wind carries a supply of fresh air down into the room below, slightly pressurising the building and increasing the outward flow of stale air.

Perimeter windows can be utilised to aid cross flow ventilation and provide fresh air coming on the windward side of the building. Stale air is exhausted through the passive stack element of the Windcatcher / Windcatcher X-Air.



Winter operation

Controls are essential to minimise ventilation heat loss. Insulated, fully modulating dampers together with the fully-automatic iNvent 2 control system linked to internal and external temperature and CO₂ sensors manage the internal heat gains and losses. This allows the system to continuously meet occupant loading without over ventilating an area, maintaining CO₂ levels in the 1000ppm to 1500ppm range.

To help ensure that the building structure is airtight, the Monodraught damper has a very low leakage rates of 2.76m³/hr/m² at 50Pa static pressure.

RANGE FEATURES LINE-UP

	Windcatcher X-Air	Sola-boost X-Air	Windcatcher Zero	Windcatcher Classic	Sola-boost Classic
Airflow Performance					
Natural Ventilation Mode	✓	✓	✓	✓	✓
Boost Ventilation Mode	X	✓	✓	X	✓
Heat Recovery Mode	X	X	✓	X	X
Cool Recovery Mode	X	X	✓	X	X
Acoustic Performance (Break through)					
Basic	✓	✓	n/a	✓	✓
25mm	✓	✓	n/a	✓	✓
50mm	✓	✓	✓	✓	✓
Features					
Activlouvres	✓	✓	✓	X	X
Supply Fan	X	✓	✓	X	✓
Extract Fan	X	X	✓	X	X
Automatic Fan Control	X	✓	✓	X	✓
Tri-Layer Protection	X	X	✓	✓	✓
Swept Dividers	✓	✓	✓	X	X
Heat Exchanger	X	X	✓	X	X
Composite Upstand	✓	✓	✓	X	X
Recyclable	✓	✓	✓	X	X
10-years No Leak Warranty	✓	✓	✓	X	X

Key features explained

- Tri-Layer Weather Protection:** consists of the external louvre bank, rain trap louvre and internal fibre mesh that together protect against extreme conditions, such as snow.
- Activlouvres:** weather resistant double-step louvre profile provides 25% more ventilation than a classic louvre profile. The modulating aerofoil louvre combines a static external louvre and a modulating internal louvre which varies the opening and free area. Provides maximum ventilation rates when fully open. Provides increasing weather resistance when partially modulated. Closes to prevent the ingress of precipitation. Comes with our unique no leak guarantee.
- INVent 2:** A bespoke natural ventilation management system designed by Monodraught for up to 4 zones of terminals. Utilises our seasonally adjusted proportional control based on temperature and CO₂ levels.

SYSTEM OPTIONS

Shape Options

		Windcatcher X-Air	Sola-boost X-Air	Windcatcher Zero	Windcatcher Classic	Sola-boost Classic
Shape	Square	✓	✓	✓	✓	✓
	Circular/Oval	X	X	X	✓	✓
	Rectangular	X	X	X	✓	✓
Colour	Medium Grey (RAL 7037)	✓	✓	✓	✓	✓
	Light Grey (RAL 7038)	X	X	X	✓	✓
	Any RAL or BS non-metallic	n/a	n/a	n/a	✓	✓
	Capping Colour	Any RAL or BS non-metallic				
Sizes	110, 140, 170, 200	140, 170, 200	170, 200	95, 125, 155, 185	95, 125, 155, 185	

Control Options



Automatic: Provided as standard. These panels are controlled by either temperature and CO₂ sensors, depending upon requirements of each specific application.



Semi-Automatic: As automatic and also allows the end user to control the opening or closing the dampers using the push button overrides.



Manual: Allows the user to operate the manual dampers by a lever at veiling diffuser level.

Installation Details

	Windcatcher X-Air	Sola-boost X-Air	Windcatcher Zero	Windcatcher Classic*	Sola-boost Classic*
Terminal Weight	110 = 120kg 140 = 150kg 170 = 183kg 200 = 215kg	140 = 160kg 170 = 195kg 200 = 230kg	170 = 235kg 200 = 265kg	95 = 70kg 125 = 100kg 155 = 130kg 185 = 170kg	95 = 80kg 125 = 115kg 155 = 150kg 185 = 190kg
Maximum Pitch Roof	35°	35°	10°	60°	60°
Inspection and clean	Annual	Annual	Annual	Annual	Annual
Filter Inspection	n/a	n/a	6-Months	n/a	n/a
External Maintenance Checks	5 years	5 years	5 years	5 years	5 years

*Weights may vary depending on the roof construction and pitch.

VENTSAIR

Ventsair Façade ventilation system (VAF)

Is a high specification louvre system designed for commercial applications and comprises of an external aluminium louvre, a volume control damper and an internal grille. Two options are available.

- **VA38 External Weather Louvre** - a small format design used extensively in education and health facilities, and retail schemes. Designed to suit a variety of different building façades. Provides controlled fresh air during the day and secure night time cooling. The external weather louvre catches any prevailing wind, whilst still ensuring there is no weather ingress. The amount of air let into the room is determined by the motorised volume control dampers that ensure an appropriate level of room ventilation.
- **VA150/VA300 Sound Attenuating Louvre** - supplied in panel format, they can be powder coated in any BS or RAL colour. Suitable for acoustically sensitive applications, they have a deeper louvre profile specially designed to reduce noise entering the room. Manufactured from 2mm aluminium sheet with 120mm acoustic infill material.



Ventsair Acoustic Air Transfer system (ATS)

A patented internal wall-mounted attenuating air transfer system that promotes cross flow ventilation within rooms to reduce heat build-up and provide fresh air. Designed to maximise air flow and minimise sound transfer. Meets the requirements of both BB93 and BB101. Options include intumescent fire damper and volume control dampers.



Ventsair Roof Mounted system

This is simply an intake or exhaust system. Whilst it's appearance is similar to the Windcatcher Classic, it does not have internal dividers. Mainly used to encourage cross flow ventilation within a room particularly where the aspect is too deep for openable windows or other wall openings. The roof mounted terminal is usually located at the far end of the room to draw the air through the room and allow warm stale air to be exhausted via the passive stack method.



NO-LEAK GUARANTEE

Monodraught's patented Windcatcher X-Air natural ventilation systems benefits from a 10 year no-leak guarantee which applies to the following products:-

- Windcatcher X-Air
- Sola-Boost X-Air
- Windcatcher Zero

This unrivalled level of weather protection for a roof mounted ventilation system guarantees that Windcatcher X-Air units will not leak for ten years thanks to three unique layers of Activlouvre weather protection.

1. Monodraught's patented modulating louvre technology allows the weather resistance of the external louvre blade to be increased dependent on weather conditions, even when closed at roof level to prevent snow being blown through its open louvre arrangement.
2. The weather resistant double-step louvre profile provides 25% more ventilation than a conventional classic louvre profile.
3. A computer designed, profiled internal rain trap louvre is fitted as standard.

The Monodraught Windcatcher X-Air systems carry a 10-year installation guarantee and the systems' control actuators are guaranteed for five years. Full T&C's are available separately.



CASE STUDY

BOBBY MOORE ACADEMY



EDUCATION



NEW BUILD



Year of installation
2018

Location
Queen Elizabeth Olympic
Park, London

Architect
Penoyre and Prasad

Consultant
MZA Consulting

Main Contractor
Halsion

Installed Systems

Natural Ventilation
Windcatcher X-Air
Ventsair façade

Hybrid Ventilation
HTM F

Control Systems
iNvent 2

Greentech ventilation systems for innovative Secondary Academy

Opened in December 2018 next to the Olympic Park in London, this new Academy provides comprehensive education for 1,000 pupils.

The building was recently shortlisted for an Education Estates award in the “Project of the Year – School” category and was also highly commended in the “Civic Building of the Year – Education New Build” category at the SPACES award ceremony in 2019.

Sustainability was a core requirement of the construction project and designed to achieve a BREEAM Excellent certification. Alongside our low carbon natural ventilation solutions, other Green features included an in-situ frame

and flat slab containing 25% recycled materials that provides thermal mass to facilitates night time cooling.

Monodraught were specified due to being market leaders of hybrid ventilation systems. The school had natural ventilation systems installed from Monodraught; our Windcatcher X-Air natural ventilation systems as well as our hybrid ventilation HTM F systems which are in use in teaching spaces.

Temperature Overview

Temperature monitoring demonstrates how the natural ventilation system controls indoor air temperature.

Zone 1 Temperature Profile

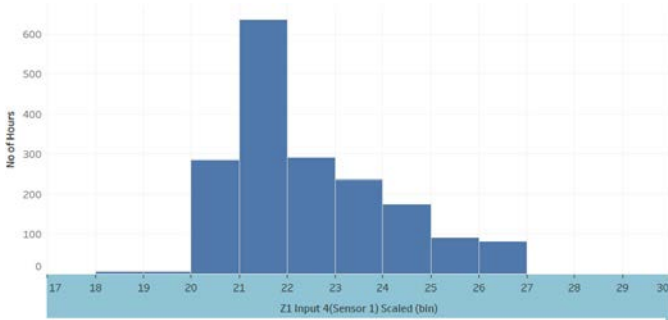

Zone 2 Temperature Profile

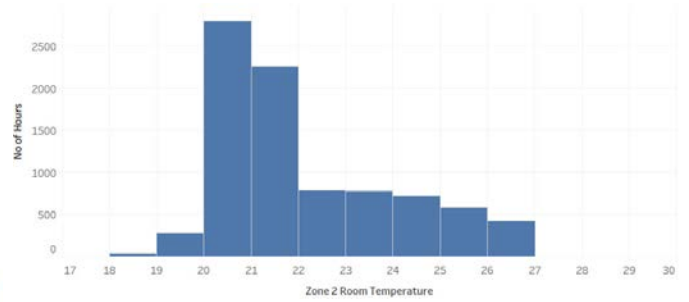

Average Monthly Temperatures

January	February	March	April	May	June	July	August	September	October	November	December
21.11	21.72	20.79	21.94	22.09	23.44	24.87	24.65	23.81	21.77	21.05	21.72

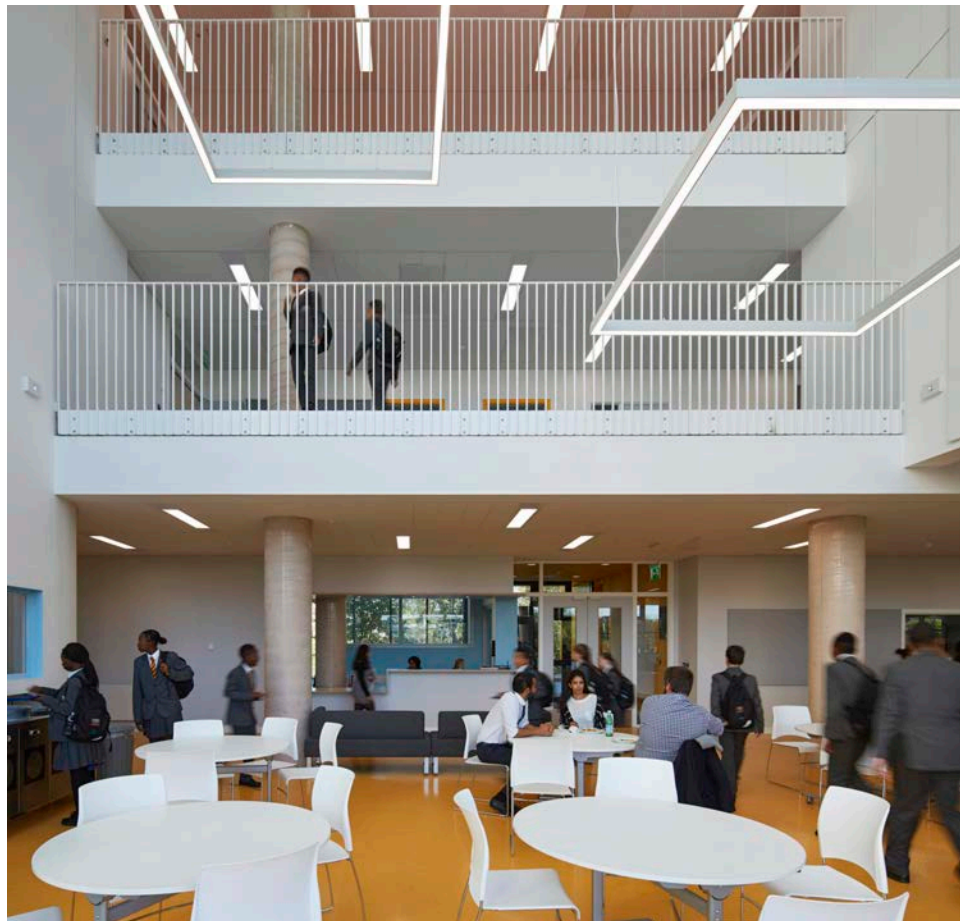

CASE STUDY

LODDISWELL PRIMARY SCHOOL



EDUCATION



NEW BUILD



Year of installation
2019

Location
Kingsbridge, Devon

End User
Devon County Council

Architects
NPS Group South West

Construction
Midas Group

Installed Systems

Natural Ventilation
Windcatcher X-Air
Ventsair façade

Control Systems
iNVent 2

Award winning, innovative, zero-carbon primary school

Loddiswell Primary opened to staff and pupils in April 2018 after a re-build from an old site which no longer met the needs of the staff and pupils. The building thermal envelope was designed to be highly sustainable and the project included many sustainable elements, such as air source heat pumps, solar panels, natural daylight and Monodraught's natural ventilation systems.

Monodraught Windcatcher X-Air natural ventilation was specified as the best solution for this sustainable new school build. Our in-house design team modelled the building and selected the most energy efficient equipment to maximise comfort and minimise running costs.

By installing our X-Air systems, the school benefits from natural fresh air and means staff and pupils enjoy a fresh environment throughout the day and avoid the typical afternoon attention

slumps when a room gets too “stuffy” or oxygen levels fall. We provide simple, user operated controls, optional data monitoring and low maintenance, minimising additional costs and unnecessary disruption in the school.

Sustainable features include PV panels which, together with the provision of air source heat pumps and fabric first approach mean that the building achieved an energy rating of A+ with a performance rating of -1. This indicates that the building has net zero carbon emissions and would usually export 1% of its total energy consumption to back to the grid. The unique design and sustainable features ensured that the building was a winner in the innovation category for The Society for Public Architecture, Construction, Engineering and Surveying (SPACES) award in 2019, after already being recognised with a gold award by the Devon Building Control Partnership.

Temperature Overview

Temperature monitoring demonstrates how the natural ventilation system controls indoor air temperature.

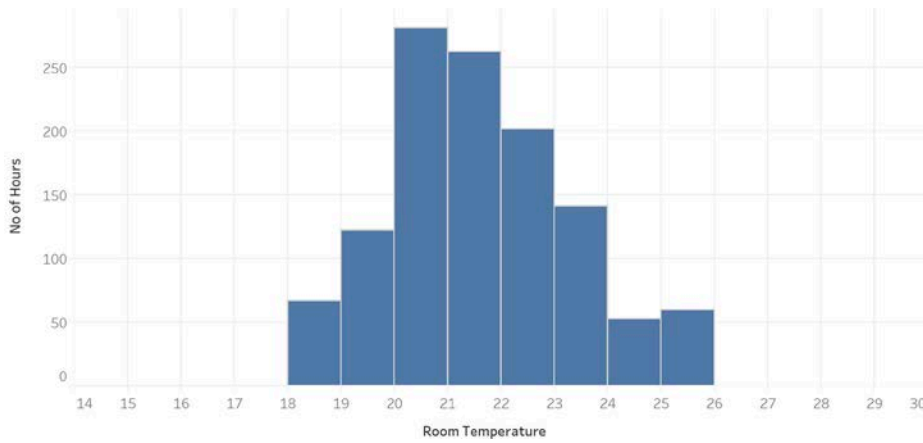

Average Monthly Temperatures

May	June	July	August	Septemb..	October	November	December	January	February
23.07	22.83	23.94	21.27	21.39	18.76	20.73	20.75	20.86	21.85



OUR SUSTAINABLE PRODUCT RANGE

Commercial buildings are utilised in many unique ways and it is essential to design ventilation and cooling strategies that match requirements. Choosing natural ventilation, hybrid ventilation and natural cooling low-carbon solutions and minimising the use of air conditioning is the logical way to meet environmental, sustainability and energy reduction goals. By cleverly combining it with the Monodraught low carbon range, it is possible to achieve a balanced approach. Regardless which products are finally selected, Monodraught engineers can provide dynamic modelling and post occupancy monitoring to ensure that indoor comfort is achieved with minimal environmental impact.



A sustainable, low carbon ventilation system that supplies fresh air to a building or room by utilising the passive effects of wind. It does not use fans or pumps making it extremely cheap to run.

Natural Ventilation
Windcatcher Zero

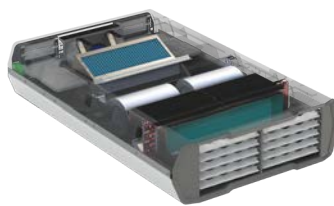

Combines the benefits of natural ventilation with a traditional mechanical ventilation system to provide low carbon natural ventilation and heating if required.

Hybrid Ventilation Heat Recovery
HVR Zero



An innovative low-energy ventilation and cooling system that uses Phase Change Material (PCM) as a thermal energy store. Uses up to 90% less energy than equivalent conventional cooling systems, does not use refrigerants and has no compressors.

Natural Cooling
Cool-phase®
Cool-phase® Hybrid



It is a single, off-site manufactured energy module which integrates Air Source Heat Pump (ASHP), Mechanical Ventilation with Heat Recovery (MVHR) and a hot water thermal heat battery. All associated ducting, pipework, pumps, valves, filters and drains are pre-fitted and factory tested to minimise time and disruption on site. Temperature and air quality monitoring, heat meters, flow sensors and energy meters are all included built-in.

Residential Energy Services Module
HomeZero



Channels daylight to indoor areas for a more productive environment whilst reducing electrical lighting costs and carbon footprint. Uses a patented high impact Diamond Dome and a Super-Silver® mirror finished aluminium tube. Available in standard and bespoke.

Natural Lighting
Sunpipe®

Monodraught WITH YOU ALL THE WAY

One home

Our Head Office in High Wycombe is home to our Sales, Design, R&D and factory teams, and is where our products are manufactured. Being located close together means our teams support you efficiently throughout your project.

Sales team

Our team works closely to support consultants, specifiers and contractors through the design and procurement process.

Building simulation

Monodraught and IES, have developed Performance Components which accurately model our products for heating and IAQ performance, as well as Part L and BREEAM compliance. Our in-house Project Design Engineers use advanced building modelling to propose the most energy efficient and low carbon solutions.

R&D and Manufacturing

Our teams continuously challenge boundaries and develops award winning products that deliver best in class solutions for our customers. By integrating advanced controls, our products deliver outstanding comfort with lowest possible running costs and highest possible carbon savings. We are accredited to ISO9001 quality management system and ISO 14001 environmental management system.

Turnkey installation and Commissioning

Our unique installation service is aligned to your construction programme and delivers over 85% of all Monodraught projects. Having received your order, our dedicated contract managers will coordinate with your programme. Our team of installers across England and Wales, and our partners in Scotland, Ireland and worldwide, visit your site ahead of installation to ensure smooth delivery. Pre-occupancy commissioning and Post Occupancy Evaluation (POE) monitoring ensure trouble-free operation.

After Sales

Our range of enhanced service and maintenance packages give peace of mind and ensure continuous operation. Through data monitoring, we can also provide ongoing analysis and assistance to optimise system performance for many years.





Monodraught

We are pioneers in the design and manufacture of advanced sustainable ventilation, cooling, heating and lighting solutions for new and refurbished commercial buildings. We deliver outstanding temperature-control and indoor air quality whilst minimising the consumption of both electricity and refrigerants so as to reduce our carbon footprint. Monodraught have over 45 years' experience and our products have saved the equivalent of nearly 390,000 tonnes CO₂ over the last two decades.

NVPB/10.2022

This publication provides information only and does not constitute an offer binding upon Monodraught Ltd. The content of this publication has been compiled to the best of Monodraught's knowledge. No express or implied warranty is given for the completeness, accuracy, reliability or fitness for particular purpose of its content and the products and services presented therein. Specifications are subject to change without prior notice. Monodraught Ltd. explicitly rejects any liability for any direct or indirect damage, in the broadest sense, arising from or related to the use and/or interpretation of this publication. All content is copyrighted by Monodraught Ltd.

Monodraught Ltd.

www.monodraught.com
info@monodraught.com
01494 897700

Halifax House, Halifax Road, High Wycombe,
Buckinghamshire, HP12 3SE, United Kingdom

